

# PIPE HB400

## THE BEST RELATION BETWEEN QUALITY AND PRICE

### TECHNICAL CHARACTERISTICS:

- **HARDENED** single wall anti-wearing pipeline having a double hardness compared to the standard one in ST52.
- Anti-wearing protection even inside the welding collars.
- It guarantees its usage until the last millimetre of thickness without sudden breaks.
- All the constraints of tolerance, pressure and security rules are respected.
- Weight per meter equivalent to a pipe in ST52.0.

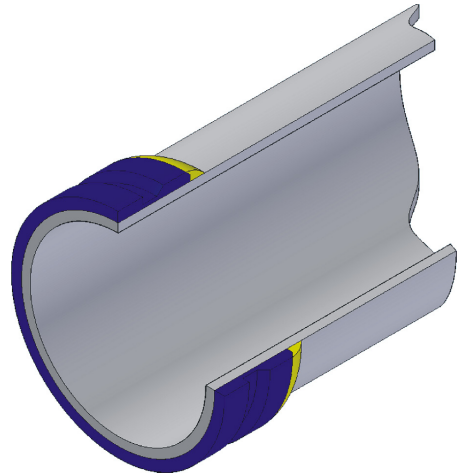

There are also available raw pipe: in rod

### ADVANTAGES:

- Life time up to 2 times more than a normal pipe in ST52.0.
- **Maximum resistance to internal and external impacts.**
- Easy workable, it is practical for quick repairs in yard and workshop.
- It has no particular problems for welding.
- Possibility of measuring the thickness using ultrasonic thickness gauge or manual device (100% product exploitation).

**“USING UNTIL THE LAST MILLIMETRE”**

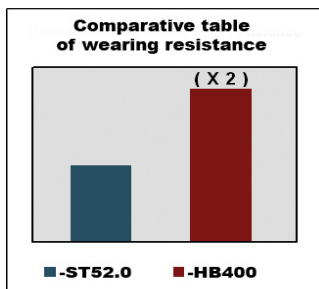

**DALCOM**® s.r.l.

MACHINERY-EQUIPMENT-SPARE PARTS

Ravenna, Italy

Tel. (+39) 0544-451513

Fax. (+39) 0544-451361

www.dalcom.it - info@dalcom.it

*“A World of technology”* >>>